



Celebrate this Week, Celebrate You!

 National Public Safety
Telecommunicators Week
April 12-18, 2020

Inside this issue

APCO President	2
Membership Information	3
Silent Key.....	3
Upcoming Webinars.....	4
Commercial Advisory	4
Bylaws Committee.....	5
Historical Committee.....	5
COVID-19.....	6
APCO Committees.....	7
Chapter Officer toolkit.....	8
ProCHRT	9
APCO Chapter Conferences.....	9
APCO Institute Class Schedule.....	10
Looking Ahead.....	10-11
Chapter Conferences.....	12-15
MCSC Committee Members.....	16
Committee Letter.....	17

*“President's Channel:**COVID 19**

Tracey M. Hilburn RPL, ENP

"The Executive Committee would like to extend to each of you our thoughts and prayers during this trying time".

"Best wishes for safety and good health".

The APCO Executive Committee would like to extend to each of you our thoughts and prayers during this trying time. It is astonishing how this pandemic has disrupted the normalcy of life, not just professionally but also personally. Who would have ever imagined we would be faced with such an unprecedented catastrophic event that would bring economic shutdown, social distancing, and place our citizens and ourselves in fear for our health and lives. As this virus has quickly inundated the country forcing response actions that we never dreamed of, just know your Executive Committee has been right there on the front line with you.

I would like to share some initiatives that have been put into motion and convey that there has been nothing more important than to stabilize APCO operations so that we can support you, our membership through these difficult times. First, a plan to secure technical services was administered while protecting the health and welfare of staff as well as looking for ways to provide you with meaningful information to help deal with this event. As this has heightened over the last two weeks our Executive Director has remained vigilant in maintaining a degree of normalcy for APCO operations so that staff is available to assist members at any time as requested or needed. APCO staff have diligently worked to support our membership by coordinating webinars affording assistance to ECCs. A web page has been devoted to COVID-19 along with a PSConnect discussion board. GRO staff remain steadfast working with Capitol Hill as potential legislation develops that can and will affect the future of 9-1-1.

While the focus for most is on COVID-19, the world is still in motion, lending to the importance of maintaining a degree of normal during these extraordinary circumstances. Internal discussions were conducted regarding the continuance of conference Flash Day, remaining with deadlines for submittals, along with continued committee work. These decisions to continue were not made lightly with all aspects of pro's and con's considered while examining the whole. We remain optimistic that APCO 2020 will occur in August, we recognize due to the existing circumstances, there is a small chance for cancellation and have added a statement to registration advising that if cancellation happened, registrants would receive a total refund. As for deadline reminders, even though we are in a crazy period of chaos and right now it is hard to fathom getting back to normal, we must remain confident that we will overcome it.

On behalf of the Executive Committee and APCO International, we express our sincere appreciation of your dedication, professionalism, and commitment. We encourage each of you to remain strong and positive while remaining safe as we work to combat this epidemic.

Best wishes for safety and good health!

*Article from APCO International

COVID-19 resources for emergency communications centers visit: apcointl.org/covid19



Membership Information

Member Type	4/1/2019	4/1/2020
Associate	2394	2368
Full Member	4328	4132
Full Group Members	6371	7922
Online Group Members	18,109	18,589
Commercial	437	462
Commercial Group Members	173	79
Total Number of Members	31,812	33,552
Total Number of Group Agencies	1055	1172
Commercial Group	37	33

Silent Key

Bradford S. Smith

Deputy Fire Chief Bradford S. Smith, a senior member of APCO International and longstanding member of the Atlantic APCO Chapter, passed away in the early morning of April 1, 2020 after waging a short, yet aggressive battle with cancer.

full obituary: psc.apcointl.org/2020/04/09/silent-key-bradford-s-smith/



Upcoming Live Webinars - Free for APCO members

Register at: <https://www.apcointl.org/webinars>

APCO Webinars are presented as live events and then made available as recordings. Most webinars are one-hour and many offer CEUs. Unless otherwise indicated, APCO webinars are free to APCO members.

Upcoming Live Webinars - Free for APCO members

▶ Cybersecurity: NG9-1-1 Best Practices & Case Studies | April 15

▶ Revolutionizing the Communications Center With Situational Awareness | April 22

COVID-19 Webinar Recordings – Free for Everyone

COVID-19 and 9-1-1: Get the Facts From CDC Officials and the Ground-Truth Perspective of a 9-1-1 Center

Thursday, April 2 | View Recording

COVID-19 Q&A With 9-1-1 Center Leaders

Friday, April 3 | View Recording

Commercial Advisory Council (CAC)

The objectives and purpose of the Commercial Advisory Council (CAC) of APCO include:

Providing guidance and support to APCO leadership and staff from the Commercial member perspective;

Supporting the Corporate Partnership Program;

Supporting chapter enhancement initiatives; and

Promoting commercial membership among peers and non-member exhibitors at the annual conference and chapter/regional conferences.



Bylaws Committee

The Bylaws committee is continuously reviewing the governing documents of the Association. We recently finished reviewing the Policy Manual at the end of the last committee year for grammatical and layout errors. When the committee finds any discrepancies, the recommendation is brought to the APCO HQ team for their input, rationale, direction, and final acceptance.

The Bylaws committee is currently midway through reviewing the Bylaws document and are projected to be finished in March 2020.

We would like to remind all Chapter officers that we are available to review any Chapters governing documents for the same reasons as we do for the Association. If any chapter is in need of a document review, please reach out to the Bylaws Committee for any assistance we can provide you.

APCO Historical Committee

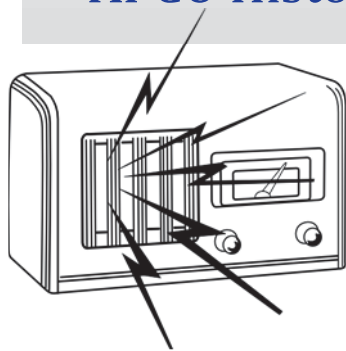

About the APCO Online Museum

APCO's Historical Committee works to capture and memorialize the many changes that have occurred during the Association's history. The artifacts you'll find in this Online Museum were contributed by former and current public safety communications professionals in an effort to share this history rich in the traditions of helping others and excellence in service. As an Association formed nearly 80 years ago, APCO International has a rich history. Since that time, the Association and the field of public safety communications have undergone myriad changes. The people, the technology, the memorabilia all weave together to tell the story of how APCO has grown to be the largest public safety communications membership association, and how the industry's capabilities have grown exponentially to keep pace with the needs of the public it serves.

<http://apco.pastperfectonline.com/>

Submissions to the Online Museum are welcome and are included at the discretion of the APCO International Historical Committee. To submit a photograph of an item, please use the online museum submission form.

For more information about the Historical Committee, visit their web page.

For questions concerning the Online Museum, please email museum@apcointl.org

9-1-1 Resources

[Warning About Malicious Website Pretending to be Coronavirus Tracker](#)

A malicious website pretending to be the live map for Coronavirus COVID-19 Global Cases by Johns Hopkins University is circulating on the internet waiting for unwitting internet users to visit the website. Visiting the website infects the user with the AZORult trojan, an information stealing program which can exfiltrate a variety of sensitive data. It is likely being spread via infected email attachments, malicious online advertisements, and social engineering. Furthermore, anyone searching the internet for a Coronavirus map could unwittingly navigate to this malicious website.

The official John Hopkins tracking map can be found here: [Global COVID-19 Case Tracker](#)

PSConnect COVID-19 Discussion Forum



APCO has created a PSConnect discussion group for members to ask questions and share information regarding the COVID-19 response and impact on emergency communications centers. This is intended to serve as a hosted discussion among members and is not monitored by APCO staff for the purpose of responding to inquiries.

This forum, and the content herein, does not represent any official position by APCO International. It is offered as a service to our members and agencies and intended for information sharing and situational awareness. The forum is not monitored by APCO Staff. For any official guidance, please refer to governmental authorities.

APCO Resources

As a reminder, all APCO EMD agency EMD instructors and EMD Managers have access to the Pandemic guide card and information in their PSConnect communities.

COVID-19 - Recommendations Regarding Caller Interrogation
General - Health and Wellness Resources

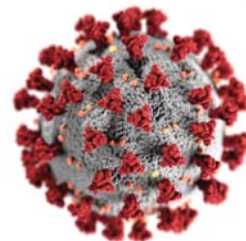

Chapter Officer Toolkit



Chapters

Chapter Officer Toolkit

- + **Best Practices**
- + **Growing the Chapter**
- + **New Chapter Member Information**
- + **Chapter Officer Guidance**
- + **Forms**
- + **Frequently Used Tools**

Check out the great resources available to chapters in the Chapter Officer Toolkit at <https://www.apcointl.org/apco-membership/chapters/chapter-officer-toolkit/>

APCO ProCHRT



The Professional Communications Human Resources Taskforce (ProCHRT) was established in 2009 to gather information, study trends, and prepare reference materials which focused on communications human resources and recognition issues across the country. The very first ProCHRT report underscored the challenges facing 9-1-1 Public Safety Communications Professionals and focused on several issues including training standards, labor laws, employee recognition, retention, and pension benefits. These reports led to the transition from Taskforce to Standing Committee in 2012.

ProCHRT provides APCO membership information regarding trending topics effecting public safety communications by monitoring PSConnect forums for trending topics. Committee members then direct members to the ProCHRT Toolbox which contains a wealth of information on training, retention, and other professional topics or create resource materials in response to the member discussions.

The committee also shares positive posts on social media platforms to raise awareness of the amazing acts members of our profession do each day to support our responders and the citizens of this nation. They also manage "Teammates in Action" the ProCHRT social media recognition program.

The ProCHRT Committee continues to foster professionalism within our community, provide timely resources and spotlight the day-to-day achievements of public safety communications professionals. If you'd like to join the group of individuals working towards these goals, volunteer today. Visit the APCO website and sign-up for the ProCHRT committee.

Young Professionals Spotlight

The APCO Young Professionals Taskforce is proud to recognize Whitney Wilson, as this quarter's young professional. Wilson is a Senior Communications Officer serving the Roswell Police Department in Georgia. In November, the twenty-six-year-old will mark her fourth year as a dispatcher.



See more about Whitney and the Young Professionals Spotlight at <https://psc.apcointl.org/2020/03/27/young-professional-spotlight-whitney-wilson-roswell-police-department/>

APCO Institute Online Class Schedule

Course Name	Dates	Course Code
Public Safety Telecommunicator 1, 7th Ed., Online	05/06/20 06/02/20	#53671
Communications Training Officer 5th Ed., Online	05/06/20 06/09/20	#53606
Fire Service Communications, 2nd Ed., Version 1, Online	05/06/20 06/16/20	#53577
Communications Center Supervisor, 5th Ed., Version 1 Instructor Update (2019), Online	05/06/20 05/26/20	#54851
Communications Center Supervisor, 5th Ed., Version 1 Instructor Update, Online	05/06/20 05/26/20	#54825
Communications Center Supervisor, 5th Ed., Version 1 Update (2019), Online	05/06/20 05/26/20	#54800
Communications Center Supervisor, 5th Ed., Version 1 Update, Online	05/06/20 05/26/20	#54775
Emergency Medical Dispatch, 5th Ed., Version 4 Instructor Update (2020), Online	05/06/20 05/26/20	#54902
Emergency Medical Dispatch, 5th Ed., Version 4, Online	05/06/20 06/16/20	#54748
Active Shooter Incidents for Public Safety Communications 2nd Ed., Online	05/13/20 06/02/20	#53545
Public Safety Telecommunicator 1, 7th Ed., Online	05/13/20 06/09/20	#53672
Communications Training Officer 5th Ed., Online	05/13/20 06/26/20	#53607
Communications Center Supervisor, 5th Ed., Version 1 Instructor Update (2019), Online	05/13/20 06/02/20	#54852
Communications Center Supervisor, 5th Ed., Version 1 Instructor Update, Online	05/13/20 06/02/20	#54826
Communications Center Supervisor, 5th Ed., Version 1 Update (2019), Online	05/13/20 06/02/20	#54801
Communications Center Supervisor, 5th Ed., Version 1 Update, Online	05/13/20 06/02/20	#54776
Communications Center Supervisor, 5th Ed., Version 1, Online	05/13/20 06/16/20	#54737
Emergency Medical Dispatch, 5th Ed., Version 4 Instructor Update (2020), Online	05/13/20 06/02/20	#54903
<u>Disaster Operations and the Communications Center, Online</u>	05/20/20 06/09/20	#53525
Public Safety Telecommunicator 1, 7th Ed., Online	05/20/20 06/16/20	#53673
Communications Training Officer 5th Ed., Online	05/20/20 06/23/20	#53608
Comprehensive Quality Online,	05/20/20 06/23/20	#53556
Communications Center Supervisor, 5th Ed., Version 1 Instructor Update (2019), Online	05/20/20 06/09/20	#54853

Advance Course Registration Required

Online Courses -- <https://www.apcointl.org/lp/online/>

Rescheduling your APCO Chapter Event



Let your MCSC Chapter Liaison know about your Chapter cancellations and postponements due to COVID-19 and we can get the word out in the monthly newsletter

Workgroup Members Needed

Getting involved on the APCO's standards development process is an excellent way to take your professional game to the next level and contribute to producing standards for public safety communications.

APCO Standards Development Working Groups Open for Sign Up:

Public Safety Communications Incident Handling Process

The Incident Handling Process standard identifies the steps and decision-making points that should be taken while processing public safety requests for service. This modified standard will also address call handling metrics based on empirical data to further refine and improve the overall process. [Sign up for this working group.](#)

Standard for Telecommunicator Emergency Response Taskforce (TERT) - NEW

The scope of this document includes information to provide guidance and helpful information regarding the development, maintenance and deployment of a Telecommunicator Emergency Response Taskforce (TERT). TERT is the concept of communications-specific mutual aid between ECCs to provide trained ECC personnel during emergency situations. This revision of the standard will assist ECCs and governing 9-1-1 authorities with the information required for developing, training, equipping and deploying a standardized TERT team. [Sign up for this working group.](#)

APCO Nexus Rescheduled in 2021



Nexus Postponed to 2021

In response to the COVID-19 virus and for the safety and welfare of everyone, APCO's [Nexus](#) event scheduled for May 21-22, 2020, in Washington, DC, has been rescheduled to May 18-19, 2021. The location will remain the same.

APCO's [Public Safety Communications Leadership in Policy Awards Dinner](#) has been rescheduled to May 18, 2021, in the same location.



2020 APCO Conference



APCO 2020

August 2-5 | Orlando, FL

REGISTRATION IS OPEN

APCO2020.ORG



CHAPTER MEMBER SERVICES COMMITTEE MEMBERS

NAME	CHAPTER ASSIGNMENT	EMAIL ADDRESS
LaMonica, Brian E. RPL	Chair	Svpsd116@gmail.com
Stroh, Melissa	Vice Chair	Melissa.stroh@isp.idaho.gov
Anderson, Jeryl	Arkansas, Missouri, Minnesota	janderson@orangecountync.gov
Brost, William	Pacific, Caribbean	wbrost.ycv@gmail.com
Diamond, David	Atlantic, Pennsylvania, Michigan	djosephdiamond@comcast.net
Entsua-Mensah, Isaac	Louisiana, Mississippi, Saudi Arabia	ie34@georgetown.edu
Essic, Travis	North Carolina, CPRA, N. California	Travis.Essic@DavidsonCountyNC.gov
Gusa, Grayson	Virginia, Mideastern, Alaska	Grayson.gusa@ncapco.org
Heimkes, Julie	Commercial	jheimkes@gmail.com
Holbrooks, Darlene	Oregon, Utah, Nevada	dholbrooks@greenvillesc.gov
Hughes, Jessica	Indiana, South Dakota	Jessica.Hughes@decaturga.com
Ivory, Roberta	Tennessee, South Carolina	Roberta.Ivory@shelbycountyttn.gov
Kempf-Barnes, Donna RPL, ENP	Newsletter Editor	dkempfbarnes@gmail.com
McCartney, Laura RPL	Kentucky, West Virginia, Ohio	mccartneylb@nnva.gov
Phillips, Elizabeth	Kansas, Nebraska, Oklahoma	lphillips@ku.edu
Raley, Catherine RPL	Colorado, Wyoming, North Dakota	craley@arapahoegov.com
Rice, Courtney - Intern	Idaho, Montana, Washington	crice@fd12.org
Scott, Laramie	Scribe	laramie.scott@clintonky911.com
Spirescu, Adriana	Arizona, New Mexico, Texas,	asprescu@ocsd.org
Townsend, Travis	Georgia, Florida, Alabama	travistownsenddale@gmail.com
Venske, Charles	Wisconsin, Iowa, Illinois	Charles.venske@hennepin.us
Martini, Stephen	Group Leader	
Hull, Rebecca	Staff Liaison	hullr@apointnl.org
Stowell Corder, Susan	Staff Liaison	stowells@apointnl.org

From the Member and Chapter Services Committee

Dear APCO Officers and Members,

The Member and Chapter Services Committee (MCSC) supports the membership at the chapter level by building relationships with chapter leaders. Each MCSC member is assigned to represent Chapters and throughout the year they maintain information flow with the chapter leaders. We are here to keep APCO members informed of association policies, governance guidelines, and other APCO programs. Just as important, we push issues from the local level to the APCO leadership level. We work for the people and strive to make sure you receive all that you can from your APCO membership.

MCSC members work diligently to get program questions or information out to the local chapters, gather the needed feedback, and get answers back to the APCO organization. We share information about programs, training, and initiatives supported by APCO International as well as upcoming events through the monthly MCSC e-Newsletter.

MCSC works to build relationships among chapter leaders through training classes and webinars hosted during the year. We also assist the APCO organization staff to provide chapter leader training and workshops at the annual conference. But, we need your help to make these things happen. You can assist us by:

- Keeping your Chapter officer list up-to-date with APCO headquarters.
- Submitting information about upcoming events or programs in your Chapter for the e-Newsletter.
- Keeping the contact information of your MCSC representative handy so if you have questions or need anything you can call on us to help.
- Participating in chapter officer calls, webinars, and training so that you are up-to-date with the current information.
- Letting your MCSC representative know who to contact in order to get information about your chapter if the President of your Chapter is not the primary contact person..
- Looking for the monthly e-Newsletter and providing us with feedback through your chapter.

We are very fortunate to have members on the MCSC who support APCO and are willing to volunteer their time to make sure that APCO can meet its vision to strengthen our communities by empowering and educating public safety communications professionals. As a committee, we look forward to continuing to work with you!

Sincerely,

Member and Chapter Services Committee