



Inside this issue

APCO President	2
Membership Information	3
Silent Key.....	3
Upcoming Webinars.....	4
Commercial Advisory	4
Bylaws Committee.....	5
Historical Committee.....	5
COVID-19.....	6
APCO Committees.....	7
Chapter Officer toolkit.....	8
ProCHRT	9
APCO Chapter Conferences.....	9
APCO Institute Class Schedule.....	10
Looking Ahead.....	10-11
Chapter Conferences.....	12-15
MCSC Committee Members.....	16
Committee Letter.....	17



Tracey M. Hilburn RPL, ENP

"I bet you haven't stopped to think about how APCO International operates through legislation, regulation, policies and governance, have you? But we do operate that way, every day and with every decision and action that is taken by your elected leaders and staff."

*Article from APCO International PCS Magazine May/June 2020

In today's ever-changing world, we are blessed, or not so blessed depending on perspective, to live based on legislation, regulation, policy and governance. On the national level, we hear our elected officials talk almost daily about legislation and regulations. In our work lives in the ECC, we deal with legislation and regulations but also with our agency policies and governance by our local governmental entity. Even what we eat is regulated by government to ensure the safety of our food.

Consider the following definitions from Merriam-Webster Dictionary.

Legislation: the exercise of the power and function of making rules that have the force of authority of a state or other organization.

Regulation: an authoritative rule dealing with details or procedure.

Policy: a definite course or method of action selected from among alternatives and in light of given conditions to guide and determine present and future decisions.

Governance: the action or manner of governing; establishment of policies and continuous monitoring of their proper implementation, by the members of a governing body. It includes the mechanisms required to balance the powers of the members with the associated accountability.

As you can see, each of these words plays a major factor in our lives, including within our federal, state and local governments, our homes, workplace, associations, clubs and even athletic events. Most of us fulfill our obligations by reporting to work, completing our daily tasks as assigned within policy, and fulfilling our responsibilities to be law-abiding citizens and family members. In our daily hustle and bustle, we tend never to think of the importance of what drives our world, our environment, our work or even our families and how the legislation, regulations, policies and governance are established. We simply go about our day-to-day endeavors and life based on rules established by others to control and oversee our actions.

I bet you haven't stopped to think about how APCO International operates through legislation, regulation, policies and governance, have you? But we do operate that

way every day with every decision and action that is taken by your elected leaders and staff. Yes, APCO International abides by much the same oversight. The same federal legislation that applies to the hiring practices and procedures in your work environment applies to APCO. All the work our government relations office does on your behalf is governed by federal legislation and regulations established by the Federal Communication Commission (FCC). APCO International also has many policies in the form of articles of incorporation, bylaws, a very detailed policy manual and a governance structure that places you at the top and includes an executive council representative from your chapter who has communications responsibilities to you and serves as the liaison between your chapter and APCO International; a board of directors elected from four regions of our country as well as our commercial members who are responsible for major decisions of this association, including budgeting and setting policy by which we operate; and the executive committee of the board, all elected by the general membership and who are entrusted with the day-to-day governance decisions of our association. And, lastly, the paid professional staff charged with carrying out the implementation of policy established by our governance bodies. So, as you can see, your association operates by legislation, regulation, policies and governance. Maintaining our association of which we are all so proud requires communication and diligence by all levels of governance to ensure that you get the information you need as our most valued asset, the 35,000 members of APCO. We all work hard to fulfill our responsibilities to you and to APCO. We all work to communicate more effectively and to ensure that we are following the governance structure for APCO to enhance our operations, communications and service to you. I would encourage each of you to become familiar with APCO's by-laws and policies. They are posted on our website in the governance section. And the next time you have questions, reach out to the executive council representative from your chapter for answers. They are charged with, along with your board of directors and executive committee, with keeping you informed. Yes, even at APCO, all of these words I have discussed — legislation, regulation, policies and governance — have a purpose.



Membership Information

Member Type	5/1/2019	5/1/2020
Associate	2504	2430
Full Member	4481	4252
Full Group Members	6468	8301
Online Group Members	18,852	18,450
Commercial	459	473
Commercial Group Members	176	122
Total Number of Members	32,840	34,028
Total Number of Group Agencies	1074	1190
Commercial Group	42	39

Silent Key

Thoughts and prayers for all the agencies that have lost a coworker during this pandemic.



Upcoming Live Webinars - Free for APCO members

Register at: <https://www.apcointl.org/webinars>

APCO Webinars are presented as live events and then made available as recordings. Most webinars are one-hour and many offer CEUs. Unless otherwise indicated, APCO webinars are free to APCO members.

We are aware that this pandemic has resulted in some of you experiencing challenging operational and training situations. If your agency currently has critical needs regarding training, the APCO Institute wants to help. Please let us know by contacting us at (386) 322-2500 or institute@apcointl.org.

COVID-19 Webinar Recordings – Free for Everyone

Commercial Advisory Council (CAC)

The objectives and purpose of the Commercial Advisory Council (CAC) of APCO include:

- Providing guidance and support to APCO leadership and staff from the Commercial member perspective;
- Supporting the Corporate Partnership Program;
- Supporting chapter enhancement initiatives; and
- Promoting commercial membership among peers and non-member exhibitors at the annual conference and chapter/regional conferences.



Bylaws Committee

The Bylaws committee is continuously reviewing the governing documents of the association. We recently finished reviewing the Policy Manual at the end of the last committee year for grammatical and layout errors. When the committee finds any discrepancies, the recommendation is brought to the APCO HQ team for their input, rationale, direction, and final acceptance.

The Bylaws committee is currently midway through reviewing the Bylaws document and are projected to be finished in March 2020.

We would like to remind all Chapter officers that we are available to review any Chapters governing documents for the same reasons as we do for the Association. If any chapter is in need of a document review, please reach out to the Bylaws committee for any assistance we can provide you.

APCO Historical Committee

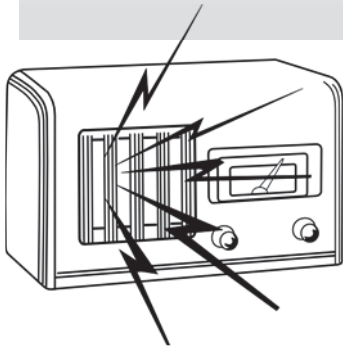

About the APCO Online Museum

APCO's Historical Committee works to capture and memorialize the many changes that have occurred during the organization's history. The artifacts you'll find in this Online Museum were contributed by former and current public safety communications professionals in an effort to share this history rich in the traditions of helping others and excellence in service. As an organization formed nearly 80 years ago, APCO International has a rich history. Since that time, the organization and the field of public safety communications have undergone myriad changes. The people, the technology, the memorabilia all weave together to tell the story of how APCO has grown to be the largest public safety communications membership organization, and how the industry's capabilities have grown exponentially to keep pace with the needs of the public it serves.

<http://apco.pastperfectonline.com/>

Submissions to the Online Museum are welcome and are included at the discretion of the APCO International Historical Committee. To submit a photograph of an item, please use the online museum submission form.

For more information about the Historical Committee, visit their web page.

For questions concerning the Online Museum, please email museum@apcointl.org

9-1-1 Resources

PSConnect COVID-19 Discussion Forum

APCO has created a PSConnect discussion group for members to ask questions and share information regarding the COVID-19 response and impact on emergency communications centers. This is intended to serve as a hosted discussion among members and is not monitored by APCO staff for the purpose of responding to inquiries.

This forum, and the content herein, does not represent any official position by APCO International. It is offered as a service to our members and agencies and intended for information sharing and situational awareness. The forum is not monitored by APCO Staff. For any official guidance, please refer to governmental authorities.

APCO Resources

APCO has created a web page dedicated to aiding APCO members in learning more about COVID-19 and how agencies can prepare. Visit apointl.org/covid19.

COVID-19 - Recommendations Regarding Caller Interrogation
General - Health and Wellness Resources

Information on COVID-19 for Emergency Communications Centers, Visit
[https://www.psconnect.org/communities/community-home?
communitykey=fffab5d-3b8d-4e09-b85b-9259f15e8fb2&tab=groupdetails](https://www.psconnect.org/communities/community-home?communitykey=fffab5d-3b8d-4e09-b85b-9259f15e8fb2&tab=groupdetails)

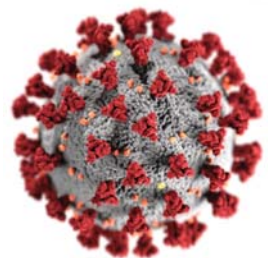

Chapter Officer Toolkit



Chapters

Chapter Officer Toolkit

- + **Best Practices**
- + **Growing the Chapter**
- + **New Chapter Member Information**
- + **Chapter Officer Guidance**
- + **Forms**
- + **Frequently Used Tools**

Check out the great resources available to chapters in the Chapter Officer Toolkit at <https://www.apcointl.org/apco-membership/chapters/chapter-officer-toolkit/>

APCO ProCHRT



ProCHRT TOOLBOX

Health and Wellness Resources

Public safety telecommunicators are devoted to assisting others every day, whether it be to help guide them through personal crisis, deal with life threatening situations, answer questions or assure them help is available. It is essential that telecommunicators take good care of themselves so they are able to better handle challenges and mitigate the impact of shift work and stress. Studies show there may be negative health effects from shift work, stress, lack of exercise or poor eating habits. The resources in this section of the ProCHRT Toolbox are designed to help individuals recognize signs of possible trouble, and to be proactive about building positive habits and striving for good mental and physical health. These resources may be adopted by an individual, or used to motivate a shift or agency to challenge themselves to work toward optimum health as a group. Check out the great resources in the ProCHRT Toolbox.

Young Professionals Spotlight

The APCO Young Professionals Taskforce recognizes Tim Stencil as this quarter's young professional spotlight. Tim is the weather coordinator, EMA liaison and assistant operations manager for Northwest Central Dispatch, located in Arlington Heights, Illinois. "I'm passionate about all things weather and love a good storm," he says. He shares his busy life with his wife of six-and-a-half years, Karen, and his two beautiful daughters Riley (4) and Claire (2 months).



See more about Tim and the Young Professionals Spotlight at <https://psc.apcointl.org/2020/01/02/young-professional-spotlight-tim-stencil-northwest-central-dispatch/>

APCO Institute Online Class Schedule

Course Name	Dates	Course Code
Bullying and Negativity in the Communications Center, 2nd Ed., Online	06/17/20 07/07/20	#53513
Emergency Medical Dispatch Manager, Online	06/17/20 07/07/20	#53495
Public Safety Communications Staffing and Employee Retention, Online	06/17/20 07/07/20	#53507
Surviving Stress, Online	06/17/20 07/07/20	#53501
Public Safety Telecommunicator 1, 7th Ed., Online	06/17/20 07/14/20	#53677
Communications Training Officer 5th Ed., Online	06/17/20 07/21/20	#53611
Communications Center Supervisor, 5th Ed., Version 1 Instructor Update (2019), Online	06/17/20 07/07/20	#54858
Communications Center Supervisor, 5th Ed., Version 1 Instructor Update, Online	06/17/20 07/07/20	#54831
Communications Center Supervisor, 5th Ed., Version 1 Update (2019), Online	06/17/20 07/07/20	#54806
Communications Center Supervisor, 5th Ed., Version 1 Update, Online	06/17/20 07/07/20	#54781
Communications Center Supervisor, 5th Ed., Version 1, Online	06/17/20 07/21/20	#54739
Emergency Medical Dispatch, 5th Ed., Version 4 Instructor Update (2020), Online	06/17/20 07/07/20	#54908
Emergency Medical Dispatch, 5th Ed., Version 4, Online	06/17/20 07/28/20	#54751
Crisis Negotiations, Online	06/10/20 06/30/20	#53562
Customer Service in Today's Public Safety Communications, Online	06/10/20 06/30/20	#53489
Disaster Operations and the Communications Center, Online	06/10/20 06/30/20	#53526
Public Safety Telecommunicator 1, 7th Ed., Online	06/10/20 07/07/20	#53676
Communications Training Officer 5th Ed., Online	06/10/20 07/14/20	#53610
Law Enforcement Communications, 1st Ed., Online	06/10/20 07/21/20	#53518
Communications Center Supervisor, 5th Ed., Version 1 Instructor Update (2019), Online	06/10/20 06/30/20	#54857
Communications Center Supervisor, 5th Ed., Version 1 Instructor Update, Online	06/10/20 06/30/20	#54830
Communications Center Supervisor, 5th Ed., Version 1 Update (2019), Online	06/10/20 06/30/20	#54805
Communications Center Supervisor, 5th Ed., Version 1 Update, Online	06/10/20 06/30/20	#54780
Emergency Medical Dispatch, 5th Ed., Version 4 Instructor Update (2020), Online	06/10/20 06/30/20	#54907

While live instructional courses are not an option at this time, we continue to have virtual options for ongoing training needs to help keep your communications center functioning and well trained.

View on-line training resources at:

<https://www.apcointl.org/training-and-certification/course-options/online-training-options/>

Rescheduling your APCO Chapter Event



Let your MCSC Chapter Liaison know about your Chapter cancellations and postponements due to COVID-19 and we can get the word out in the monthly newsletter

Workgroup Members Needed

Getting involved on the APCO's standards development process is an excellent way to take your professional game to the next level and contribute to producing standards for public safety communications.

APCO Standards Development Working Groups Open for Sign Up:

Public Safety Communications Incident Handling Process

The Incident Handling Process standard identifies the steps and decision-making points that should be taken while processing public safety requests for service. This modified standard will also address call handling metrics based on empirical data to further refine and improve the overall process.

To sign up for a work group visit:

<https://www.apcointl.org/standards/how-to-assist-with-standards-development/join-a-working-group/>



APCO Nexus Rescheduled in 2021



Nexus Postponed to 2021

In response to the COVID-19 virus and for the safety and welfare of everyone, APCO's [Nexus](#) event scheduled for May 21-22, 2020, in Washington, DC, has been rescheduled to May 18-19, 2021. The location will remain the same.

APCO's [Public Safety Communications Leadership in Policy Awards Dinner](#) has been rescheduled to May 18, 2021, in the same location.



2020 APCO Conference



APCO 2020

August 2-5 | Orlando, FL

REGISTRATION IS OPEN

APCO2020.ORG



CHAPTER MEMBER SERVICES COMMITTEE MEMBERS

NAME	CHAPTER ASSIGNMENT	EMAIL ADDRESS
LaMonica, Brian E. RPL	Chair	Svpsd116@gmail.com
Stroh, Melissa	Vice Chair	Melissa.stroh@isp.idaho.gov
Anderson, Jeryl	Arkansas, Missouri, Minnesota	janderson@orangecountync.gov
Brost, William	Pacific, Caribbean	wbrost.ycv@gmail.com
Diamond, David	Atlantic, Pennsylvania, Michigan	djosephdiamond@comcast.net
Entsua-Mensah, Isaac	Louisiana, Mississippi, Saudi Arabia	ie34@georgetown.edu
Essic, Travis	North Carolina, CPRA, N. California	Travis.Essic@DavidsonCountyNC.gov
Gusa, Grayson	Virginia, Mideastern, Alaska	Grayson.gusa@ncapco.org
Heimkes, Julie	Commercial	jheimkes@gmail.com
Holbrooks, Darlene	Oregon, Utah, Nevada	dholbrooks@greenvillesc.gov
Hughes, Jessica	Indiana, South Dakota	Jessica.Hughes@decaturga.com
Ivory, Roberta	Tennessee, South Carolina	Roberta.Ivory@shelbycountyttn.gov
Kempf-Barnes, Donna RPL, ENP	Newsletter Editor	dkempfbarnes@gmail.com
McCartney, Laura RPL	Kentucky, West Virginia, Ohio	mccartneylb@nnva.gov
Phillips, Elizabeth	Kansas, Nebraska, Oklahoma	lphillips@ku.edu
Raley, Catherine RPL	Colorado, Wyoming, North Dakota	craley@arapahoegov.com
Rice, Courtney - Intern	Idaho, Montana, Washington	crice@fd12.org
Scott, Laramie	Scribe	laramie.scott@clintonky911.com
Spirescu, Adriana	Arizona, New Mexico, Texas,	aspirecu@ocsd.org
Townsend, Travis	Georgia, Florida, Alabama	travistownsenddale@gmail.com
Venske, Charles	Wisconsin, Iowa, Illinois	Charles.venske@hennepin.us
Martini, Stephen	Group Leader	
Hull, Rebecca	Staff Liaison	hullr@apointnl.org
Stowell Corder, Susan	Staff Liaison	stowells@apointnl.org

From the Member and Chapter Services Committee

Dear APCO Officers and Members,

The Member and Chapter Services Committee (MCSC) supports the membership at the chapter level by building relationships with chapter leaders. Each MCSC member is assigned to represent Chapters and throughout the year they maintain information flow with the chapter leaders. We are here to keep APCO members informed of association policies, governance guidelines, and other APCO programs. Just as important, we push issues from the local level to the APCO leadership level. We work for the people and strive to make sure you receive all that you can from your APCO membership.

MCSC members work diligently to get program questions or information out to the local chapters, gather the needed feedback, and get answers back to the APCO organization. We share information about programs, training, and initiatives supported by APCO International as well as upcoming events through the monthly MCSC e-Newsletter.

MCSC works to build relationships among chapter leaders through training classes and webinars hosted during the year. We also assist the APCO organization staff to provide chapter leader training and workshops at the annual conference. But, we need your help to make these things happen. You can assist us by:

- Keeping your Chapter officer list up-to-date with APCO headquarters.
- Submitting information about upcoming events or programs in your Chapter for the e-Newsletter.
- Keeping the contact information of your MCSC representative handy so if you have questions or need anything you can call on us to help.
- Participating in chapter officer calls, webinars, and training so that you are up-to-date with the current information.
- Letting your MCSC representative know who to contact in order to get information about your chapter if the President of your Chapter is not the primary contact person..
- Looking for the monthly e-Newsletter and providing us with feedback through your chapter.

We are very fortunate to have members on the MCSC who support APCO and are willing to volunteer their time to make sure that APCO can meet its vision to strengthen our communities by empowering and educating public safety communications professionals. As a committee, we look forward to continuing to work with you!

Sincerely,

Member and Chapter Services Committee